

#YourGrowthMachine



L958H Wheel Loader

The power-packed performer.



Gross Power: 230HP@2150rpm

Operating Weight: 18250KG

Payload: 5500KG

CEV-IV Certified

Member of the Volvo Group

Technical Specifications

Standard Equipment

Engine	
Engine model	WP7G234E501
Engine type	In-line, water-cooled, direct injection
Gross Power hp	230 @ 2150 rpm
Maximum torque Nm	1000 @ 1400 rpm
Displacement (ml)	7470
Number of cylinders	6
Bore / stroke (mm)	108 /136
Emission standard	CEV IV
Transmission System	
Make	SDLG
Type	Counter shaft electric liquid shift
No. of gears	4 Forward and 4 Reverse
Torque converter	Single stage four element twin turbine torque convertor
Machine speed F1, F2, F3, F4 (km/h)	0~6.7/12.4/25.9/38
Machine speed R1, R2, R3, R4 (km/h)	0~6.8/12.5/26.1/38.2
Axles	
Make	SDLG make with Dry Disc brakes
Front & Rear	A515 Series heavy duty axles with 36 ton carrying capacity
Rear Axle Oscillation (°)	±13°
Hydraulic system	
Type	Single joystick pilot hydraulic control
Pilot system working pressure (MPa)	3.5
Main Pump	Gear Pump
Maximum flow (ltrs/min)	348
System working pressure (MPa)	16
Hydraulic cycle time Sec	
Bucket lift time (full load)	≤5.7 s
Bucket fall time (no load)	≤3.7 s
Bucket dumping time (no load)	≤1.2 s
Total cycle time	≤10.6 s
Steering System	
Type	Load-sensing full hydraulic articulated steering
Working pressure of steering system (MPa)	16
Steering angle (°)	38°
Steering pump flow (lpm)	222
Brake system	
Service brake	Air over hydraulic disc brakes with single brake pedal
Parking brake	Electric air-controlled caliper disc brake
Brake pressure (MPa)	0.784
Tyres	
Tyre size	23.5~25 L3
Front Tyre pressure (MPa)	0.39±0.01
Rear tyre pressure (MPa)	0.33±0.01
Cabin	
Cabin Type	ROPS / FOPS Certified
AC	Standard with dual filters
Operator seat	Mechanical suspension seat
Music System	MP3 Player with Bluetooth Mobile connection
Seat belt	Standard
Performance	
Payload capacity	5500 kg
Bucket volume, Heaped ISO/SAE Cu.m (GP)	3.2
Operating weight kg	18250 kg
Maximum breakout force (kN)	≥170
Maximum traction force (kN)	≥160
Static Tipping Load Straight (kN)	≥121
Static Tipping Load Full Turn (kN)	≥100
Electrical system	
Voltage	24V
Batteries	2

Dimension		
A. Overall length (mm)	8730	
B. Wheelbase (mm)	3300	
C. Overall height (mm)	3410	
D. Minimum ground clearance (mm)	420	
E. Maximum dumping height (mm)	3500	
F. Hinge pin at maximum lift height (mm)	4540	
G. Corresponding dump reach (mm)	1130	
H. Maximum dumping height (mm)	3500	
J. Dumping angle (°)	-45°	
L. Overall width (mm)	3024	
M. Outside width of wheel (mm)	2785	
N. Wheel tread (mm)	2190	
O. Min. turning radius outside rear wheel (mm)	5890	
P. Horizontal crossing radius outside bucket (mm)	6910	
System Refill Capacity		Interval (hrs)
Diesel filling capacity of fuel tank (L)	300	
Hydraulic Oil tank filling capacity (L)	220	2000
Transmission oil filling capacity (L)	17.1 / 4.7	First 50 / Every 1000
Oil filling capacity of braking system (L)	4	
Oil filling capacity of axles (main drive and wheel reducer) (L)	30 + 30	First 50 / Every 1000
Engine oil filling capacity (L)	22	500
Antifreeze coolant (L)	55	2000
Optional Attachments		
HD Bucket (m³)	2.7 / 3	
LM Bucket (m³)	5	
Long grapple	Available	
Pallet fork	Available	
Pre-cleaner	Oil bath pre-cleaner	
Side Discharge Bucket	Available	

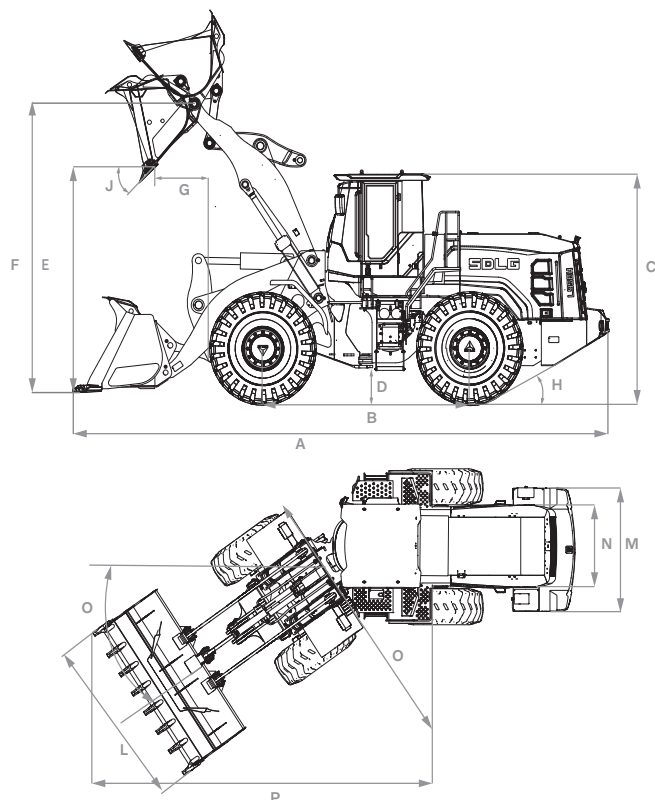

Connect with us on: [f](#) [y](#) [in](#)
 Whatsapp: [+](#)91 99453 69456
 Toll Free: 1800-108-6856
www.sdlgindia.com

