

#YourGrowthMachine



Motor Grader G9190HVHP

Built for heavy
duty applications



Gross Power: 197hp @ 2200rpm

Operating Weight: 15800KG

Member of the Volvo Group

Technical Specifications

Standard Equipment

| Engine | |
|--|---|
| Engine model | WP7G200E501 |
| Engine type | In-line, water-cooled, four-stroke, direct injection |
| Gross Power hp @ 2200 rpm | 197 |
| Maximum torque Nm @ 1500 rpm | 900 |
| Displacement (ml) | 7470 |
| Number of cylinders | 6 |
| Bore / stroke (mm) | 108 /136 |
| Transmission System | |
| Make | ZF6WG200 |
| Type | Counter-shaft, power shift, auto manual |
| No. of gears | F6 and R3 |
| Torque converter | Single Stage Single Phase three Element |
| Machine speed F1, F2, F3, F4, F5, F6 (km/h) | 0~5/8.5/11.5/20/25/40 |
| Machine speed R1, R2, R3 (km/h) | 0~5/11.5/25 |
| Rear Axle & Tandem | |
| Make | SDLG |
| Ground clearance (mm) | 430 |
| Differential | No Slip |
| Oscillation (°) | ±15° |
| Front Axle | |
| Oscillation (°) | ±16° |
| Wheel Lean (°) | ±18° |
| Ground clearance (mm) | 610 |
| Hydraulic System | |
| Type | Load sensing hydraulic system |
| Pump | Variable Piston pump |
| Rated Flow | 75ml/r |
| Rated Pressure | 20MPa |
| Control Valve | 9 Spool |
| Steering System | |
| Type | Load-sensing hydraulic steering |
| Steering Angle (°) | ±50° |
| Turning radius (mm) | 7600 |
| Brake System | |
| Service Brake | MICO single-circuit system with nitrogen charged accumulators. Outboard mounted hydraulically operated. |
| Parking Brake | Mechanical control on transmission |
| Cabin | |
| ROS/FOPS compliant | Standard |
| AC | Standard with dual filters |
| Operator seat | Mechanical suspension seat |
| Music system | MP3 Player with blue-tooth mobile connection |
| Seat Belt | Standard |
| Electrical system | |
| Voltage | 24V |
| Batteries | 2 |
| Dimension | |
| A. Overall length (mm) | 8975 |
| B Blade base(mm) | 2569 |
| C Wheel Base (mm) | 6480 |
| D Wheel track (mm) | 2270 |
| E Overall width (mm) | 2710 |
| F Overall Height (mm) | 3240 |

| Mold Board Turn circle & Blade range | |
|--------------------------------------|------|
| Moldboard lift above ground | 445 |
| Blade width (mm) | 635 |
| Blade length (mm) | 3657 |
| Blade tilt angle (°) | 90 |
| Blade down force | 7787 |
| Blade Slewing angle(°) | 360 |
| Cutter diameter(mm) | 1626 |
| Blade Max. Depth in Ground (mm) | 787 |

| Noise dB | |
|--------------------|-----|
| Operator ear level | 74 |
| Pass by | 107 |

| Tires | |
|-----------|---------------------------|
| Tire size | 17.5- 25 Ply rating: 16PR |

| Operating Weight | |
|------------------|-------|
| Front axle | 4700 |
| Rear axle | 11100 |
| Total machine | 15800 |

- ### Optional Attachments
- Front Dozer Blade
 - Mid Mount Scarifier
 - Rear Ripper
 - Auto Blade Lift

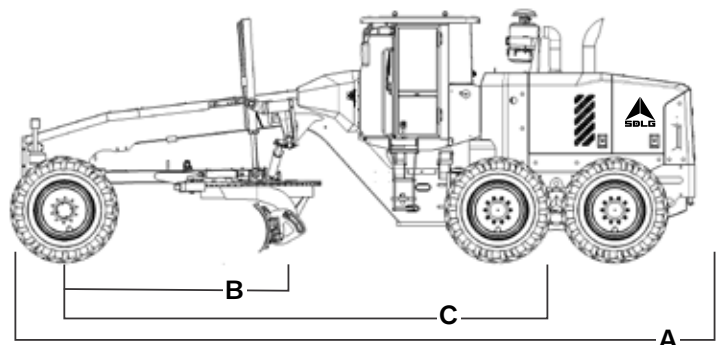
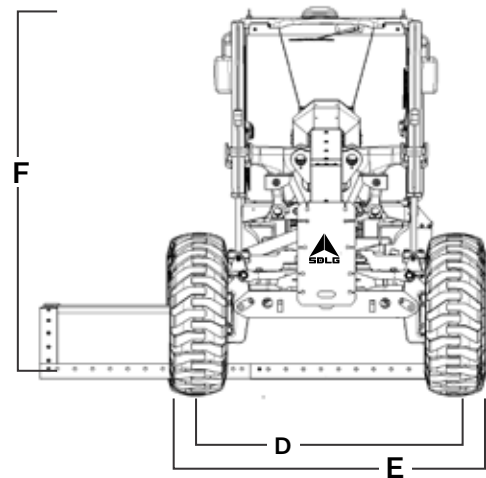

Connect with us on: [f](#) [y](#) [t](#)
 Whatsapp: [+](#)91 99453 69456
 Toll Free: 1800-108-6856
www.sdlgindia.com

