

#YourGrowthMachine



# Motor Grader G9138H

Delivers speed and  
versatility.



Gross Power: 148hp @ 2200rpm

Operating Weight: 13000 KG

Total Blade Length: 3658 mm

---

CEV-IV Certified

---

Member of the Volvo Group

# Technical Specifications

## Standard Equipment

Engine	
Engine model	WP4.6NG150E501
Engine type	Four-valve, four-cylinder, in-line, water-cooled, four-stroke, direct injection
Gross power hp @ 2200 rpm	148
Maximum torque Nm @ 1500	640
Displacement (ml)	4580
Number of cylinders	4
Bore / stroke (mm)	108 / 125
Transmission System	
Make	6WG 158
Type	Counter shaft power shift Auto manual
No. of gears	F6 and R3
Torque converter type	Single stage single-phase three element
Machine speed F1, F2, F3, F4, F5, F6 (km/h)	0-4.8/8.5/10/17/24.5/39
Machine speed R1, R2, R3	0-4.8/10/24.5
Rear Axle & Tandem	
Make	SDLG
Ground clearance (mm)	400
Differential	No Spin
Oscillation	±15°
Front Axle	
Oscillation	±16°
Wheel Lean	±18°
Ground clearance	590 mm
Hydraulic System	
Type	Opened type system
Pump	Gear pump
Rated Flow ml/r	25
Rated Pressure Mpa	18
Steering System	
Type	Load-sensing and hydraulic steering
Steering Angle	±50°
Turning radius mm	6500
Brake	
Service Brake	MICO single-circuit system with nitrogen charged accumulators. Outboard mounted hydraulically operated.
Parking Brake	Mechanical control on transmission
Cabin	
ROS/ FOPS Compliant	Standard
AC	Standard with dual filters
Operator seat	Mechanical suspension seat
Music system	FM, MP3 Player with blue-tooth mobile connection
Seat Belt	Standard
Electrical System	
Power	24V
Batteries	2
Machine Dimension	
A. Overall Length (mm)	8120
B. Blade Base (mm)	2250
C. Wheel Base (mm)	6040
D. Wheel Track (mm)	2070
E. Overall Width (mm)	2410
F. Overall Height (mm)	3235
Mold Board Turn circle & Blade range	
Mold board lift above ground (mm)	380
Blade width (mm)	580
Blade length (mm)	3658
Blade tilt angle (°)	90
Cutting diameter (mm)	1375
Blade Max. Depth in Ground (mm)	575
Blade down force (kg)	6112
Noise dB	
Operator ear level	78
Pass by	107
Tyres	
Tyre size	14.00 - 24 and 16PR

Operating Weight kg	
Front Axle	3700
Rear Axle	9300
Total Machine	13000
Optional Attachments	
Front Dozer Blade	
Mid Mount Scarifier	
Rear Ripper	
Auto Blade Lift	
Blade Overload Protection System	

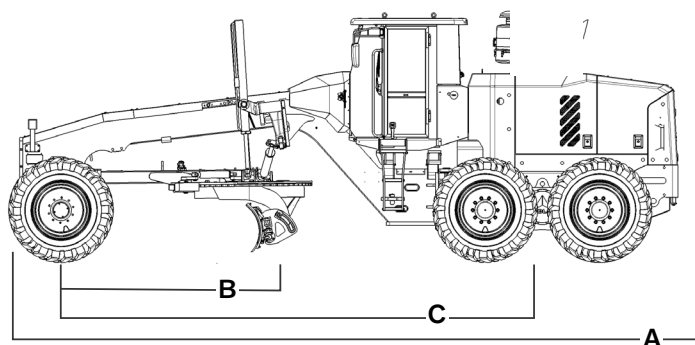
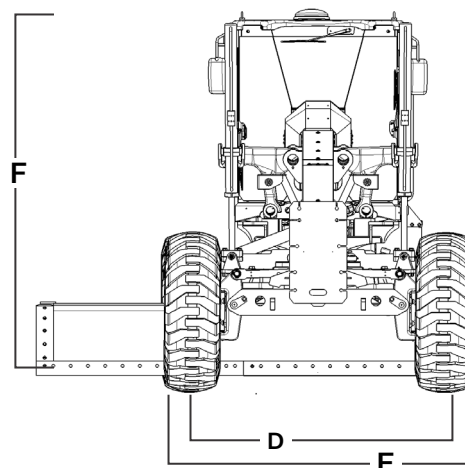

Connect with us on: [f](#) [v](#) [in](#)

Whatsapp: [+91 99453 69456](#)

Toll Free: 1800-108-6856

[www.sdlgindia.com](http://www.sdlgindia.com)

